

**SİZİN KALİTENİZ.**  
QUALITY BELONGS TO YOU.



**ÖZRAY**  
Asansör Ray Sistemleri  
Elevator Rail Systems

# HAKKIMIZDA / ABOUT US / درباره ما

Özray Asansör San. Ve Tic. A.Ş.; arttırılmış 1.400.000 metre/yıl asansör rayı ve bağlantı ekipmanları üretim kapasitesiyle, İzmir'deki 8.000m<sup>2</sup>'lik üretim tesislerinde 1988 yılında kurulmuştur.

Deneyimli Ar-Ge departmanımız, asansör sektöründeki teknolojik gelişmeleri yakından takip edip, bu gelişmeleri üretimimize uygulayarak müşterilerimizin talep ve ihtiyaçlarını karşılamak için çalışmakta olup, kalite kontrol ekibimiz üretimimizin her safhasını kontrol ederek ISO, CE ve TSE uluslararası kalite standartlarında müşterilerimize yüksek kalitede kusursuz ürün sunmamızı sağlamaktadır.

Uzun soluklu ticari iş birliğini hedefleyen firmamızın asıl önceliği müşteri memnuniyeti olduğu için satış sonrası ekibimiz ile müşterimizden gelen her türlü geri bildirimini dikkate alıp takip ederek müşterilerimize satış sonrası teknik destek sunmaktadır.

Tüm Türkiye'de gelişmiş bayi ağı ile müşterilerine hizmet sunan Özray Asansör, uluslararası pazarda da yüksek kalitedeki ürün ve hizmetleriyle pazar payını arttırmayı hedeflemektedir.

---

As OZRAY, which was established in 1988 on 8.000m<sup>2</sup> area, we are the manufacturer of the elevator guide rails and connection equipment in our Izmir factory with the improved production capacity which is 1.400.000 meters per year.

With our well experienced Research & Development Team we are following the day by day improving high technology in the elevator market and implement the improvements into our production lines to be able to satisfy the needs and wants of our customers.

Our products are always being under control of our Quality Assurance Team in the every process of our production to be able to provide high quality products to our customers under the ISO, TSE and CE quality standards.

By being a customer oriented company, we always follow up closely our customers feedbacks and support them with our after sales service by aiming to establish long-term co-operation hence our main priority is our customers satisfaction.

Providing its products and services by the advanced distributor network in all over the Turkey, OZRAY is aiming to increase its market share in the international market with its high quality products and services.

---

کمپانی ÖZRAY فعالیت خود را از سال 1988 در زمینه تولید ریلهای هادی آسانسور با بهره گیری از تکنولوژی پیشرفته روز آغاز کرده است. هم اکنون ما به ظرفیت تولید 1400000 متر ریل در هر ماه رسیده ایم که تحقق این امر با پیروی از تکنولوژی پیشرفته در زمینه بازار آسانسور میسر شده است. کلیه محصولات پیش از تولید در بخش تحقیق و توسعه مورد بررسی قرار گرفته و سپس به بخش توسعه پروژه و مرکز سنجش کیفیت فرستاده میشوند. شرکت ما دارای نرخهای استاندارد و نماینده فروش در سراسر ترکیه میباشد.

İzmir'deki tesisimizde sadece asansör rayı ve bağlantı ekipmanlarına odaklı kalite ve kontrol öncelikli üretimimizi her gün bir adım ileriye taşıyarak sürdürmekteyiz.

In our Izmir facilities, we maintain our production by improving everyday our elevator guide rails and connection equipment focused production with our quality priority.

تسهیلات کمپانی ما در ازمیر تولید تجهیزات ریلهای آسانسور میباشد، تمرکز ما بر روی تضمین کیفیت محصولاتمان بوده و هدف ما پیشرفت روز افزون میباشد.





**BOY STANDARDI  
LENGHT STANDARDIZATION**



1

**Raylar kesim işlemleri sonrası standart boya getirilir.**

After the cutting process in band-saw machinery the length standardization of all our products is obtained.

در جهت استاندارد سازی ارتفاع ، کلیه محصولات ما توسط ماشینهای اره نواری پردازش میشوند.

# 2

**Rayların dikey ve yatay açılarını dođrultma işleminin sonrasında standart hale getirilir.**

Horizontal and vertical angles are standardized by the rectify process.

در ابتدا محصولات ما جهت استاندارد شدن زوایای افقی و عمودی اصلاح میشوند.





**DIKEY VE YATAY DOĞRULTMA**  
**VERTICAL AND HORIZONTAL RECTIFICATION**



**YÜZEYSEL PRES İŞLEMİ**  
**SURFACE PRESS PROCESS**



# 3

Yanal açılarını düzeltmek için ürünlere milimetrik yüzeysel pres işemi uygulanır.

The surface press process is used to adjust the millimetric lateral angle.

برای چك كردن خطاهای میلیمتری از پرس سطح استفاده میکنیم.

# 4

**Vargel makinalarında rayların baş kısımları talaş kaldırarak standart ölçülere getirilir.**

Rail grinding machinery is used to provide height standard by removing the chips on top of the guide rails.

در جهت حفظ نهایت استاندارد میلیمتری در ارتفاع و صیقلی و هموار بودن سطح، از دستگاه سنگ زنی استفاده میکنیم.





**YÜKSEKLİK STANDARDI - YÜZEY PÜRÜZSÜZLÜĞÜ**  
**HEIGHT STANDARDIZATION - SURFACE SMOOTHNESS**



**YÜZEY ZIMPARA VE CİLALAMA**  
**SURFACE SANDING AND POLISHING**



# 5

**Raylar zımpara işleminden geçirilerek standart yüzey pürüzsüzlüğü sağlanır.**

By sanding process the smoothness standardization on the guide rails are obtained.

در آخرین مرحله برای صیقلی کردن سطح و استاندارد کردن ابعاد، روی و بالای سطح مجدداً صیقل داده میشود.

# 6

**Kusursuz flanş bağlantısının yapılması için ray tabanları CNC makineler ile taşlanır.**

To make a perfect connection, the fishplates are being grinded with CNC machinery for the basic adjustments.

برای بهترین اتصال در فلنجهای، از دستگاههای سی ان سی در تنظیمات ابتدایی استفاده میکنیم.



A close-up photograph of a CNC lathe machining a metal flange. The workpiece is a dark, cylindrical metal part with a flange-like structure. The lathe tool is visible, cutting the metal. The background is a blurred industrial setting with orange and grey tones. The text is overlaid at the bottom of the image.

**KUSURSUZ FLANŞ BAĞLANTISI İÇİN CNC İŞLEMİ**  
**CNC PROCESS FOR PERFECT FLANGE CONNECTIONS**



**KANAL İŞLEMİ**  
**DUCTING PROCESS**





# 7

**Rayların birbirlerine kusursuz monte edilebilmeleri için ray kenarlarına kanallar açılır.**

For a flawless assembling, ducting process is applied on the sides of the guide rails.

برای اتصال ریلها به یکدیگر فرایند داکتینگ در نهایت حساسیت اعمال میشود.

# 8

Ray delikleri pres ile açılır.

The bolt holes are opened by press process.

در فرایند پرس کردن سوراخهای پیچ را ایجاد میکنیم.





**CIVATA DELİKLERİ**  
**BOLT HOLES**



**HAVŞA YERİ**  
**COUNTERSINK PLACE**

# 9

**Ray deliklerinin bulunduĐu yerlere aĐı temassızlık problemi yařanmaması iĐin havřa yeri aĐılır.**

Countersink places are opened on the bolt hole places to prevent the connection and angle losse problems.

برای جلوگیری از هر گونه بر هم خوردگی زاویه ای در نصب و راه اندازی از فضای انبساطی استفاده میکنیم.

# 10

**Raylar otomatik boya ve yađlama makinamızdan geirilerek kalite kontrol departmanının onayına hazır hale getirilir.**

The products are made ready for the Quality Assurance team control after the automatic dyeing and lubrication machine process

مراحل رنگ آمیزی و روانسازی كاملا اتوماتيك بوده و بدون هيچگونه دخالت انسانی انجام ميشوند.





**BOYAMA-YAĞLAMA**  
**DYEING-LUBING**



**AMBALAJLAMA  
PACKAGING**





# 11

**Üretimden çıkan ürünlerimiz kalite kontrolden geçtikten sonra ambalajlanarak sevkiyata hazır hale getirilir.**

All of our finished products, after the confirmation of our Quality Assurance team's control, are being packed to be ready to dispatch.

سرانجام محصولات ما به صورت بسته بندی شده در اختیار مشتریان ما قرار خواهند گرفت.

# TEKNİK ÇİZİMLER TECHNICAL DRAWINGS

90x75x16

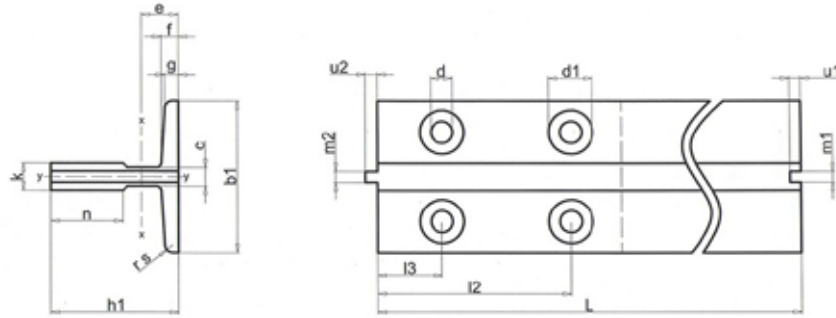

ölçü	b1	h1	h	k	n	c	g	f	rs	q1 kg/ms	x+y	m1	m2	u1	u2	d	b2	b3	l1	l2	l3	L
tolerans	±1,5	±0,75	±0,1	0 +0,1	0 +0,3		±0,75	±0,75				0 +0,06	0 -0,06	±0,1	±0,1		±0,5	±0,2	0 +3	±0,2	±0,2	±2
90x75x16	90	75	74	16	42	10	8	10	4	13,5	90°	6,4	6,37	7,14	6,35	13	90	57,2	305	114,3	38,1	5000

89x62x16

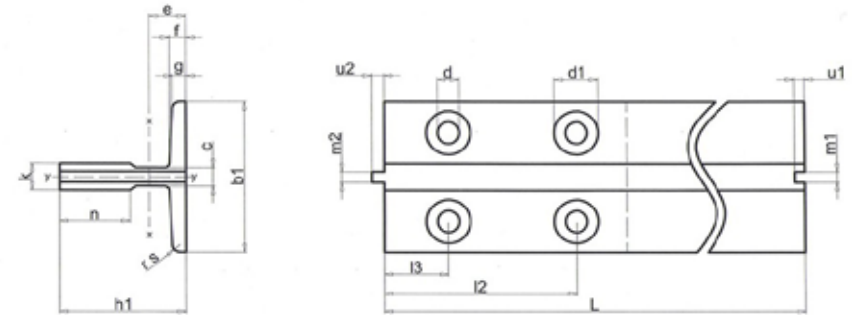

ölçü	b1	h1	h	k	n	c	g	f	rs	q1 kg/ms	x+y	m1	m2	u1	u2	d	b2	b3	l1	l2	l3	L
tolerans	±1,5	±0,75	±0,1	0 +0,1	0 +0,3		±0,75	±0,75				0 +0,06	0 -0,06	±0,1	±0,1		±0,5	±0,2	0 +3	±0,2	±0,2	±2
89x62x16	89	62	61	16	34	10	7,9	11,1	3	12,4	90°	6,4	6,37	7,14	6,35	13	90	57,2	305	114,3	38,1	5000

70x65x9

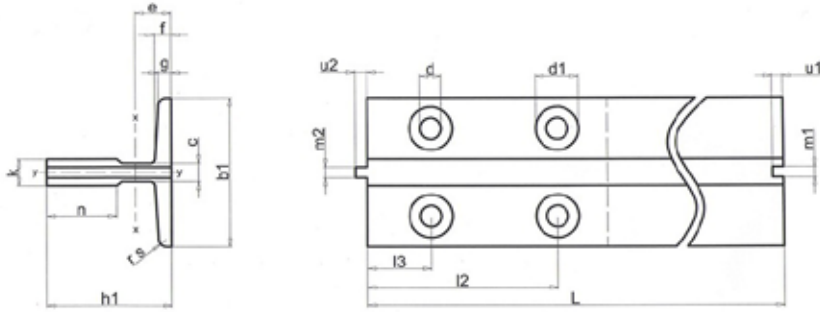

ölçü	b1	h1	h	k	n	c	g	f	rs	q1 kg/ms	x1y	m1	m2	u1	u2	d	b2	b3	l1	l2	l3	L
tolerans	±1,5	±0,75	±0,1	0 +0,1	0 +3		±0,75	±0,75				0 +0,06	0 -0,06	±0,1	±0,1		±0,5	±0,2	0 +3	±0,2	±0,2	±2
70x65x9	70	65	64	9	34	6	6	8	1,5	7,5	90°	3	2,97	3,5	3	13	70	42	250	105	25	5000

50x50x5

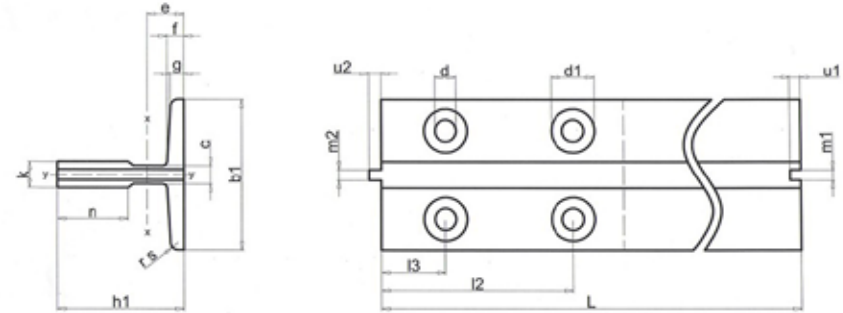

ölçü	b1	h1	h	k	n	c	g	f	rs	q1 kg/ms	x1y	m1	m2	u1	u2	d	b2	b3	l1	l2	l3	L
tolerans	±0,5	±0,5	±0,1	0 +0,1			±0,1	±0,2				0 +0,06	0 -0,06	±0,1	±0,1		±0,5	±0,2	0 +3	±0,2	±0,2	±2
50x50x5	50	50	49	5	27	4,5	5	5,4	1	3,7	90°	2,6	2,55	3,5	3	9	50	30	200	75	25	5000



Zeki Öztaş Cad. No: 68 Ayrancılar, Torbalı / İZMİR  
Tel: +90 232 854 80 07 Faks: +90 232 854 71 42  
E-posta: info@ozray.com.tr Web: www.ozray.com.tr

ÖZRAY Mobil Uygulama



ÖZRAY Mobile APP